

VANKIT

Internal Van Racking Specialists

Generic Installation Instructions

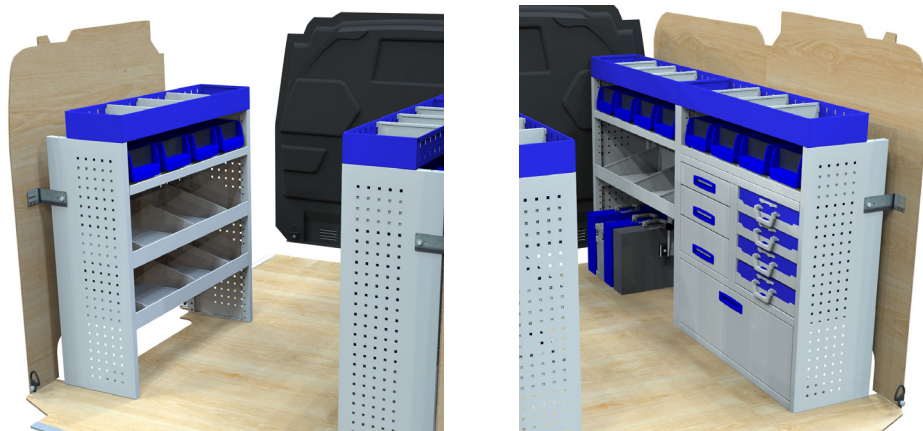

Tools Required

Drill (Cordless) // Rivet Tool

4.0mm & 8.5mm HSS Drill Bit

2x 13mm Spanners // Impact Driver (optional)

Vankit (UK) Ltd cannot be held responsible for any damage caused to your van, you must check and be careful prior to drilling any holes.

Single Unit Installation

Position the unit within the van where you would like it.

Using the L brackets, position to the sides of the units where there would be **metal work** behind the ply-lining- generally where the ply lining is screwed to the vehicle. If in doubt, unscrew some of the ply-lining to see where the metal work is.

Once the brackets are located in position, using a pen/marker, mark on the side of the unit where the larger oblong hole is & on the side of the van where the smaller 4mm holes are located.

Drill an 8.5mm hole into the side of the unit where the oblong mark is and using a 4mm drill bit, drill 4x 4mm holes through the ply-lining and metal work.

Make sure the drill bit does not pierce the outer of the van! You shouldn't need to drill anymore then 10mm.

Loosely attach the brackets to the units using the M8x20mm bolts, washers & nyloc nuts.

Rivet the brackets to the side of the van & tighten the M8 Bolts & Nuts. Repeat this process for both sides of the units.

Tip!

Every Van is different and bracket positioning may vary. You may need to drill another hole through the bracket.

Floor Fixing

We recommend getting at least 1x M8x40mm bolt through the floor on each unit.

Make sure you check under the van to not drill into anything (like the fuel tank!)

For the remaining floor holes, use the 8x $\frac{3}{4}$ Self Tappers with the M6 Washers to secure to the floor.

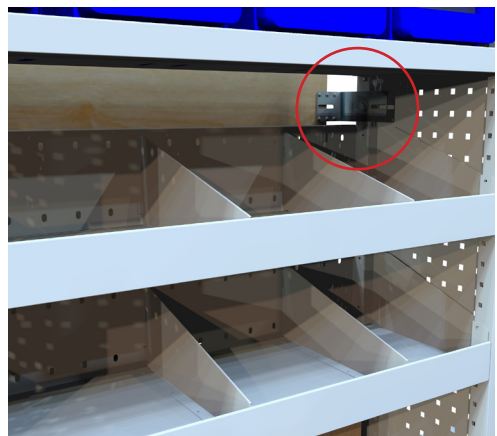

Double Unit Installation

Position both of the units within the van where you would like it.

Using the L brackets, position to the sides of the units where there would be **metal work** behind the ply-lining- use the 3rd bracket in the middle of the two units

Once the brackets are located in position, using a pen/marker, mark on the side of the unit where the larger oblong hole is & on the side of the van where the smaller 4mm holes are located.

Drill an 8.5mm hole into the side of the unit where the oblong mark is and using a 4mm drill bit, drill 4x 4mm holes through the ply-lining and metal work.

Make sure the drill bit does not pierce the outer of the van! You shouldn't need to drill anymore then 10mm.

Loosely attach the brackets to the units using the M8x20mm bolts, washers & nyloc nuts. Join the units together using the M8x12mm bolts, Washers & Flange Nuts

Rivet the brackets to the side of the van & tighten the M8 Bolts & Nuts. Repeat this process for both sides of the units.

Tip!

Every Van is different and bracket positioning may vary. You may need to drill another hole through the bracket.

Floor Fixing

We recommend getting at least 1x M8x40mm bolt through the floor on each unit.

Make sure you check under the van to not drill into anything (like the fuel tank!)

For the remaining floor holes, use the 8x¾ Self Tappers with the M6 Washers to secure to the floor.

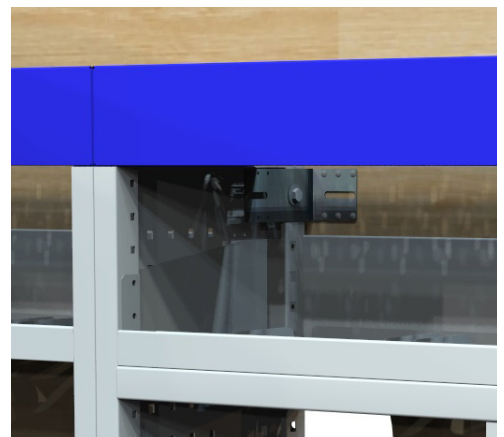
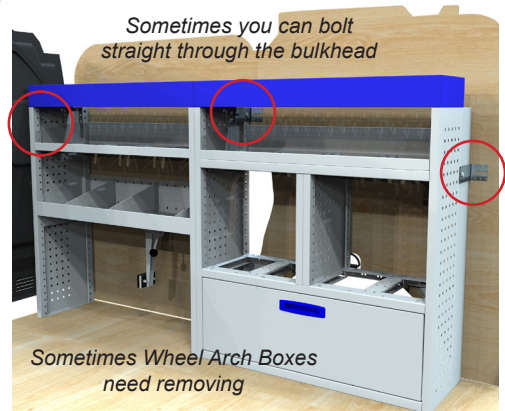

Drawer Installation



105mm Height Drawers = Gap of 2 Holes
140mm Height Drawers = Gap of 3 Holes
175mm Height Drawers = Gap of 4 Holes
210mm Height Drawers = Gap of 5 Holes

Drawer Gliders have an 'L' profile that the drawers sit on. Left & Right Gliders are marked with either an L or R

Slide the back end of the glider into the rear square hole at the back of the unit (normally starting at the bottom). Occasionally the glider nib may need opening a fraction with a flat head screw driver.

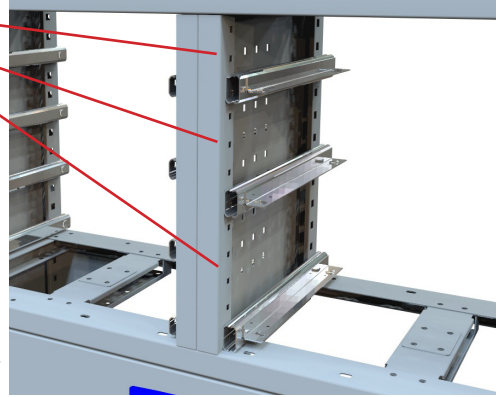

'Click' the front end of the glider into the front square hole. Repeat process for all left & right gliders. Make sure they are positioned according to drawer heights (see above).

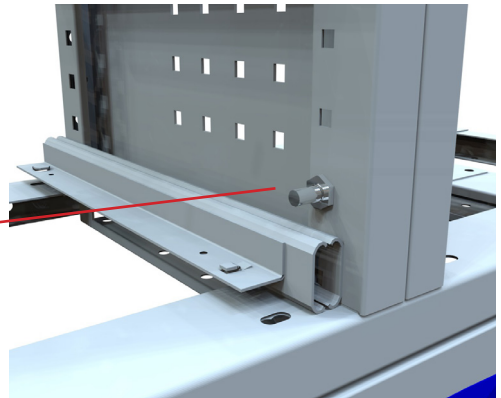

In each drawer there are 2 locking pins. Insert the locking pin from inside of the side panel just above the glider. Screw the nut on and tighten with 13mm spanner & pliers.

Repeat the process for all gliders & locking pins.

Fully extend 1 pair of gliders and place the appropriate drawer on top loosely.

Slide the drawer into the glider nibs at the back of the drawer both sides.

'Click' the glider nibs into the front of the drawer both sides.

Repeat the process for all drawers.

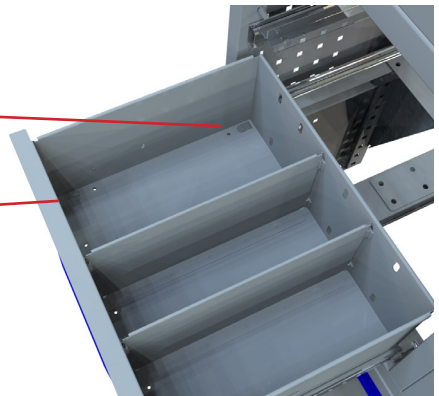

Case Tray Installation

All standard cases will leave a gap of 2 holes between each glider.

Case Tray Gliders **DO NOT** have an 'L' profile. Left & Right Gliders are marked with either an L or R

Slide the back end of the glider into the rear square hole at the back of the unit (normally starting at the bottom). Occasionally the glider nib may need opening a fraction with a flat head screw driver.

'Click' the front end of the glider into the front square hole. Repeat process for all left & right gliders.

Repeat the process for all gliders.

Fully extend 1 pair of gliders and place the case tray (TFSC) on top.

Slide the case tray into the glider nibs at the back of the TFSC both sides.

'Click' the glider nibs into the front of the TFSC on both sides.

Repeat the process for all case trays.

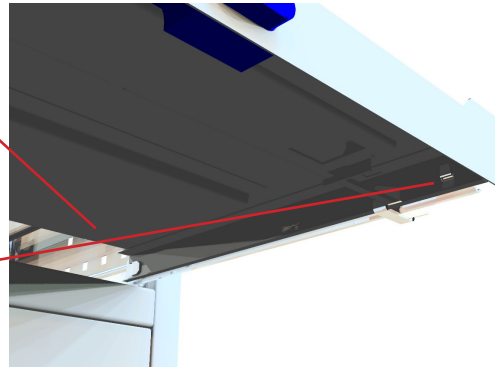
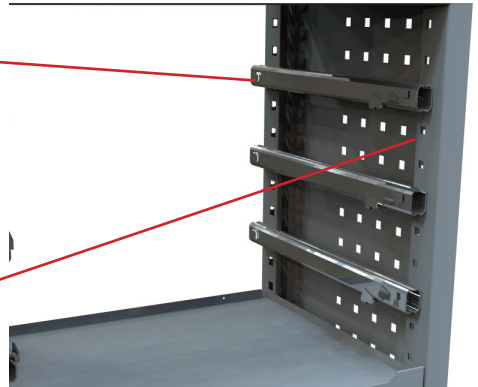
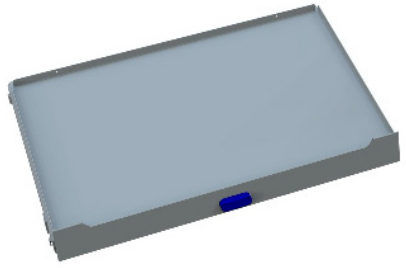

VANKIT

Internal Van Racking Specialists